

Warm Up...

Find the volume of these figures...

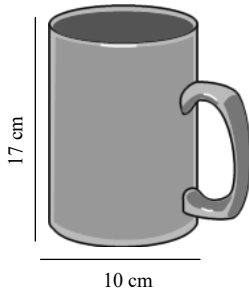

Solution???

$$\begin{aligned}
 V &= A_{\text{base}} \times \text{height} \\
 &= \pi r^2 h \\
 &= \pi (5)^2 (17) \\
 &= 1335.2 \text{ cm}^3
 \end{aligned}$$

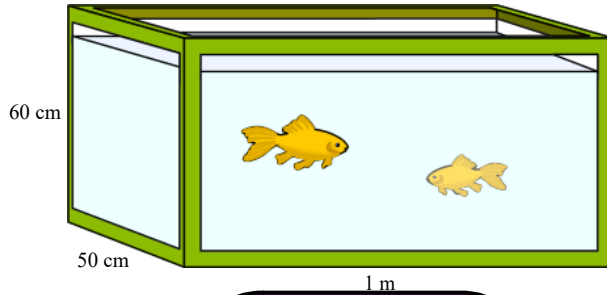

Solution???

$$\begin{aligned}
 V &= l \times w \times h \\
 &= (100)(50)(60) \\
 &= 300\,000 \text{ cm}^3 \times \left(\frac{1\text{m}}{100\text{cm}}\right)^3
 \end{aligned}$$

May 2-10:54 AM

6.3 - Volume and Capacity of Prisms and Cylinders

Math on the Job... Page 246

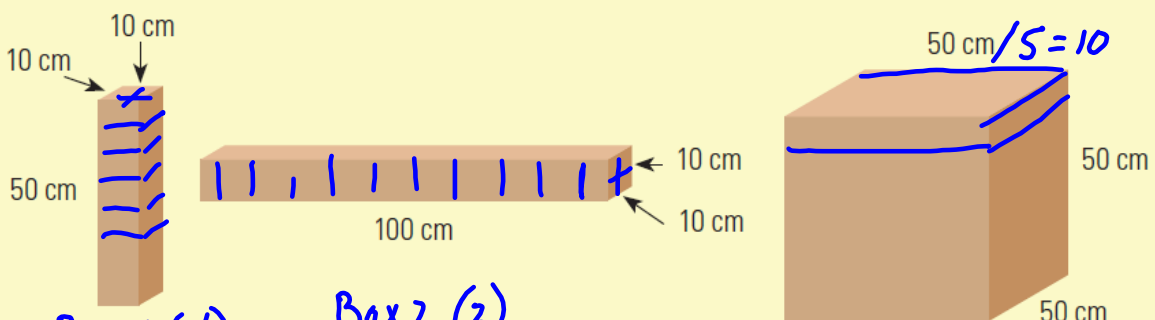

Box 1 (4)

Box 2 (2)

Box 3 holds 10x10x10

$$\begin{aligned}
 &5\text{cm} \\
 \frac{50}{5} &= 10
 \end{aligned}$$

$$\begin{aligned}
 10 \times 4 &= 40 \text{ / box} \\
 \frac{160}{40} &= 4 \text{ boxes}
 \end{aligned}$$

$$\begin{aligned}
 \text{Box 2} \\
 \frac{100}{5} &= 20 \\
 20 \times 4 &= 80 \text{ cubes} \\
 160 \div 80 &= 2 \text{ boxes}
 \end{aligned}$$

= 1000
too big

Oct 24-8:04 PM

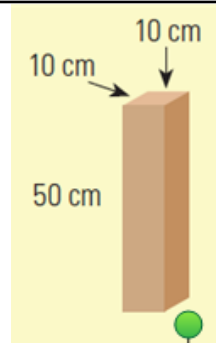
**SOLUTION**

In the first carton, Gordon would have to arrange the boxes so that 2 fit along the width ($10 \text{ cm} \div 5 \text{ cm}$), 2 fit along the length ($10 \text{ cm} \div 5 \text{ cm}$), and 10 fit within the height ($50 \text{ cm} \div 5 \text{ cm}$). This carton would fit 40 boxes ($2 \times 2 \times 10$). Gordon could ship the boxes in 4 of these cartons ($160 \div 40$).

Oct 26-10:02 AM

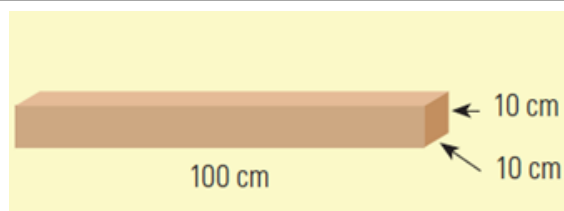

In the second box, Gordon could fit 20 boxes along the length ($100 \text{ cm} \div 5 \text{ cm}$), 2 along the width ($10 \text{ cm} \div 5 \text{ cm}$), and 2 boxes within the height ($10 \text{ cm} \div 5 \text{ cm}$). This box would only fit 80 boxes ($20 \times 2 \times 2$). Gordon could ship the boxes in 2 of these cartons ($160 \div 80$).

Oct 26-10:03 AM

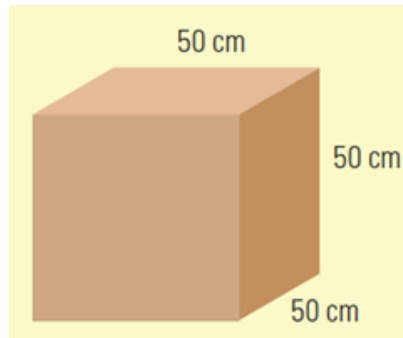

In the third box, Gordon could fit 10 boxes along the length ($50 \text{ cm} \div 5 \text{ cm}$), 10 boxes along the width ($50 \text{ cm} \div 5 \text{ cm}$), and 10 boxes within the height ($50 \text{ cm} \div 5 \text{ cm}$). The box would fit 1000 of the smaller boxes ($10 \times 10 \times 10$). This carton is much too big for the shipment.

Oct 26-10:03 AM

Volume

versus

Capacity

- amount of space an object takes up.
- all objects have volume.
- measured in cubed units.

- amount of material that can be contained in a hollow volume.
- measured in such as litres and gallons.

* hollow objects have volume and capacity while solid objects only have volume.

Remember...

$$1 \text{ cm}^3 = 1 \text{ mL}$$

How Volume and Capacity are Related

$$1 \text{ cm}^3 = 1 \text{ mL}$$

$$1 \text{ m}^3 = 1000 \text{ L}$$

$$1000 \text{ cm}^3 = 1 \text{ L}$$

Oct 24-8:14 PM

Finding the Volume of a Rectangle Prisms...

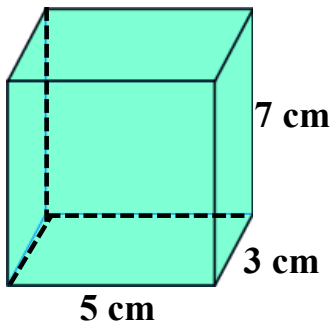

Formula???

$$\begin{aligned} V &= l \times w \times h \\ &= (5)(3)(7) \\ &= 105 \text{ cm}^3 \end{aligned}$$

Oct 24-8:51 PM

Finding the Volume of a Triangle Prism...

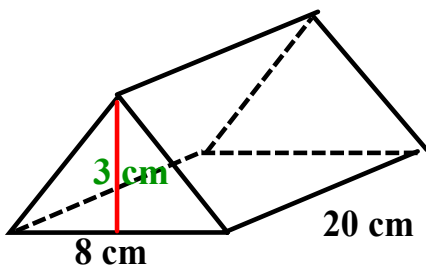

Formula???

$$\begin{aligned} V &= A_{\text{base}} \times h \\ &= \frac{bh}{2} \times l \\ &= \frac{(8)(3)}{2} \times 20 \\ &= 240 \text{ cm}^3 \end{aligned}$$

Oct 24-8:53 PM

Finding the Volume of a Cylinder...

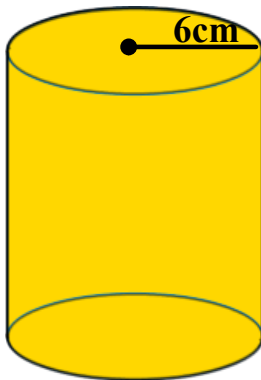

Formula???

$$\begin{aligned} V &= A_{\text{base}} \times h \\ &= \pi r^2 h \\ &= \pi (6)^2 (8) \\ &= 904.8 \text{ cm}^3 \end{aligned}$$

Oct 24-8:55 PM

Note: The volume of any prism can be found by taking the area of the base and multiplying by the height.

$$V_{\text{prism}} = A_{\text{base}} \times \text{height}$$

Oct 24-8:59 PM

Exercise: Find the volume of each figure...

1)

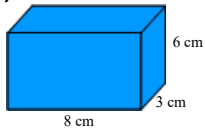

$$V = l \times w \times h$$

$$= (8)(3)(6)$$

$$= 144 \text{ cm}^3$$

2)

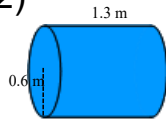

$$V = A_{\text{base}} \times h$$

$$= \pi r^2 h$$

$$= \pi (0.6)^2 (1.3)$$

$$= 1.47 \text{ m}^3$$

3)

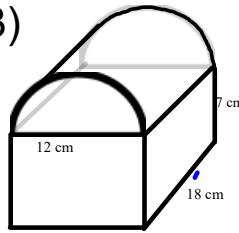

$$V = l \times w \times h + \frac{\pi r^2 h}{2}$$

$$= 12(18)(7) + \frac{\pi (6)^2 (7)}{2}$$

$$\approx 1512 + 1017.9$$

$$= 2529.9 \text{ cm}^3$$

4)

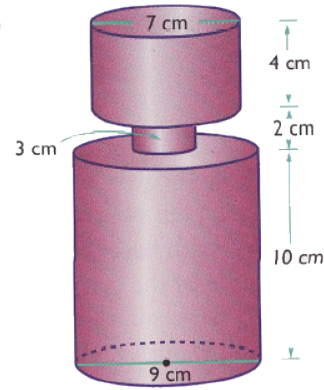

$$V = \pi r^2 h + \pi r^2 h + \pi r^2 h$$

$$= \pi (4.5)^2 (10) + \pi (1.5)^2 (2) + \pi (3.5)^2 (4)$$

$$= 49\pi + 4.5\pi + 202.5\pi$$

$$= 256\pi$$

$$\approx 804.2 \text{ cm}^3$$

Oct 24-9:02 PM

TRY THIS ONE...

A swimming pool needs to be filled with water. It costs \$0.005/L to fill the pool. How much will it cost to fill the rest of the swimming pool?

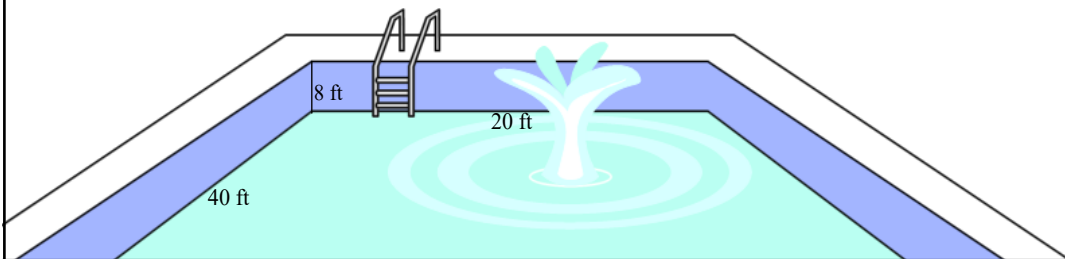

$$V = l \times w \times h$$

$$= 40(20)(8)$$

$$= 6400 \text{ ft}^3$$

SOL'N?

$$6400 \text{ ft}^3 \times \left(\frac{12 \text{ in}}{\text{ft}}\right)^3 \times \left(\frac{2.54 \text{ cm}}{\text{in}}\right)^3 \times \frac{1 \text{ m}^3}{1 \text{ cm}^3} \times \frac{1 \text{ L}}{1000 \text{ ml}} = 181227.8 \text{ L}$$

$$\frac{\$0.005}{\text{L}} \times 181227.8 \text{ L} = \$906.14 \text{ to fill the pool}$$

May 2-10:56 AM

ACTIVITY 6.5
VOLUME OF AN OBLIQUE PRISM

Tatyana and Sherri have been asked to find the volume of the oblique rectangular prism below.



Sherri doesn't think that it is possible to find the volume since it is not a rectangular prism. Tatyana remembers that you can find the area of a parallelogram by turning it into a rectangle.



With a partner, decide if you can find the volume of an oblique rectangular prism using the same method. Be prepared to defend your position to the rest of your class.

SOLUTION

Lead students to discover that the volume of the prism can be found in the same way the area of a rectangular prism can be found. So the volume would still be found by using $V = \ell \times w \times h$. The volume of the prism is 1445 cm^3 .

$$V_{\text{prism}} = A_{\text{base}} \times \text{height}$$

Oct 24-8:25 PM

DISCUSS THE IDEAS Page 250

INVESTIGATING VOLUME



Planters are an attractive way to create an outdoor space.

Makayla is a landscaper. She will be planting flowers in 15 planters. There are three sizes of planters she can use. She has to determine how much soil will go into each so she knows how much soil to buy. The planters come as three cubic boxes, one with 1-ft sides, a second with 2-ft sides, and a third with 4-ft sides.

1. Determine the volume of each box.

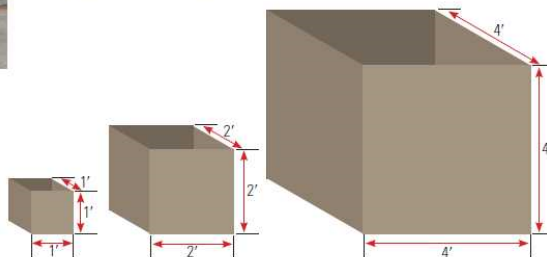

- As the side length is doubled, what happens to the volume? Explain why you think this is the case.
- If she has five of each size of planter, how much soil, in cubic feet, does she need?

SOLUTIONS

1. Determine the volume of each box.

1-ft box: $V = (1)^3$
 $V = 1 \text{ ft}^3$

2-ft box: $V = (2)^3$
 $V = 8 \text{ ft}^3$

4-ft box: $V = (4)^3$
 $V = 64 \text{ ft}^3$

2. As the side length is increased by 2, the volume is increased by a factor of 8. This is because each of the three side lengths has been doubled, so the volume is increased by 2 times 2 or 2^3 .

To get the volume of a new box where a scale factor has been applied equally to all sides, multiply the original volume by the cube of the scale factor.

3. Use the volume calculations from question 1 to solve the problem.

1-ft box:
 $V = 1 \text{ ft}^3$
 $1 \times 5 = 5 \text{ ft}^3$

2-ft box:
 $V = 8 \text{ ft}^3$
 $8 \times 5 = 40 \text{ ft}^3$

4-ft box:
 $V = 64 \text{ ft}^3$
 $64 \times 5 = 320 \text{ ft}^3$

Add to find the answer.
 $5 + 40 + 320 = 365$

Julia will need 365 ft^3 of soil.

Oct 24-8:31 PM

HOMEWORK...

Page 252: #1 - 6

1. a)

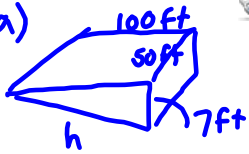

6.3 - Build Your Skills Solutions.pdf

$$\begin{aligned}
 b) \quad V &= A_{\text{base}} \times h \\
 &= \frac{bh}{2} \times w \\
 &= \frac{100(7)}{2} \times 50 \\
 &= 17\,500 \text{ ft}^3 \\
 17\,500 \text{ ft}^3 &\times \frac{7.48 \text{ gal}}{1 \text{ ft}^3} \\
 &= 130\,900 \text{ gal}
 \end{aligned}$$

$$\begin{aligned}
 c^2 &= a^2 + b^2 \\
 h^2 &= 7^2 + 100^2 \\
 &= 49 + 10\,000 \\
 &= 10\,049 \\
 h &= \frac{\sqrt{10\,049}}{100.2} \text{ ft}
 \end{aligned}$$

$$\begin{aligned}
 c) \quad S.A. &= \frac{2bh}{2} + lw + lw \\
 &= \frac{2(100)7}{2} + 7(50) \\
 &\quad + (100.2)(50) \\
 &= 700 + 350 + 5010 \\
 &= 6060 \text{ ft}^2
 \end{aligned}$$

Oct 24-8:36 PM

6.3 - Build Your Skills Solutions.pdf