



4.3 - Surface Area

Make Connections

The ancient pyramids at Giza, Egypt, were built about 4500 years ago.

This pyramid has a square base with a side length of 755 feet. The original height of the pyramid was 481 feet. Archeologists believe that the pyramid was once covered with a white limestone casing. How could you calculate the area that was once covered with limestone?





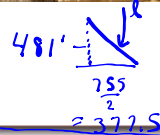

$$\text{Slant height} = \sqrt{481^2 + 377.5^2}$$

$$= 611.45 \text{ ft}$$

$$A = 4 \text{ triangles}$$

$$= 4 \left(\frac{bh}{2} \right)$$

$$= 4 \left(\frac{(755)(611.45)}{2} \right)$$

$$= 923289.5 \text{ ft}^2$$

AREA Formulas...

Rectangle or Square



$A = bh$

Circle

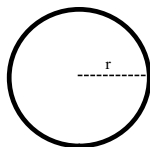

$A = \pi r^2$

Triangle

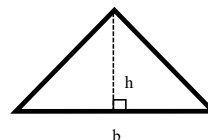

$A = \frac{1}{2} bh$

$$A = \frac{bh}{2}$$

Parallelogram or Rhombus

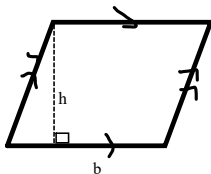

$A = bh$

Trapezoid

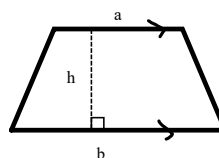

$A = \frac{1}{2} h(a + b)$

$$A = \frac{(a+b)h}{2}$$

Surface Area

Surface area is the total area of all of the faces of the object.

Steps need to find Surface area are:

1. Draw all of the faces with dimensions displayed on them.
2. Find the area of each face.
3. Then add up the areas of all of the faces.

Activate Prior Learning:

Surface Areas of Right Prisms and Cylinders

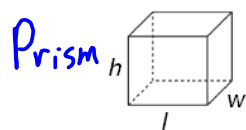

$$SA = 2wl + 2hl + 2hw$$



$$SA = 2\pi r^2 + 2\pi rh$$

Which object below has the greater surface area?

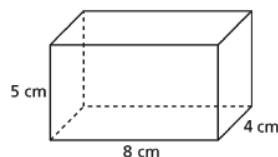

$$SA = 2wl + 2wh + 2lh$$

$$\begin{aligned} &= 2(4)(8) + 2(4)(5) + 2(8)(5) \\ &= 64 + 40 + 80 \\ &= 184 \text{ cm}^2 \end{aligned}$$

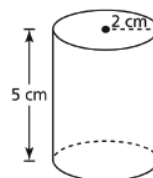

$$\begin{aligned} A &= 2\pi r^2 + 2\pi rh \\ &= 2\pi(2)^2 + 2\pi(2)(5) \\ &= 8\pi + 20\pi \\ &= 28\pi \\ &= 87.96 \text{ cm}^2 \end{aligned}$$

1.4 Surface Areas of Right Pyramids and Right Cones

The surface area of a prism is equal to the sum of the areas of its faces. For a rectangular prism with length ℓ , width w , and height h , the surface area is $S = 2\ell w + 2\ell h + 2wh$.

EXAMPLE 1 Find the surface area of the rectangular prism.

$$S = 2\ell w + 2\ell h + 2wh$$

$$S = 2(3)(5) + 2(3)(7) + 2(5)(7)$$

$$S = 142$$

Surface area of a prism

$$\ell = 3, w = 5, h = 7$$

Simplify.

The surface area is 142 square feet.

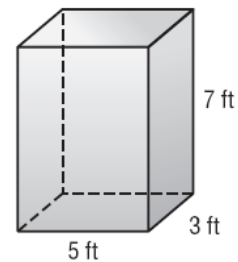

The surface area S of a cylinder with height h and radius r is the area of the two bases plus the area of the curved surface, or $S = 2\pi r^2 + 2\pi rh$.

 **SOLUTION**
(Erase to reveal)

The surface area S of a cylinder with height h and radius r is the area of the two bases plus the area of the curved surface, or $S = 2\pi r^2 + 2\pi rh$.

EXAMPLE 2 Find the surface area of the cylinder.
Round to the nearest tenth.

$$S = 2\pi r^2 + 2\pi rh$$

$$= 2\pi(5)^2 + 2\pi(5)(9)$$

$$= 50\pi + 90\pi$$

$$= 140\pi$$

$$= 439.8 \text{ m}^2$$

Surface area of a cylinder

$$r = 5, h = 9$$

Simplify.

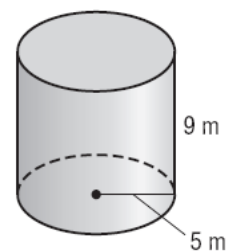



 **SOLUTION**
(Erase to reveal)

Class/Homework

Worksheet on Prisms & Pyramids

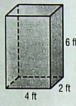
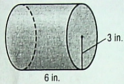
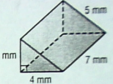
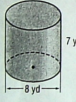
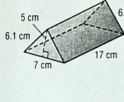
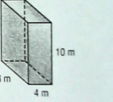
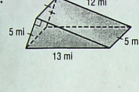
necessary.

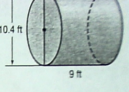
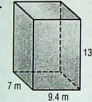
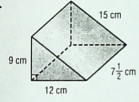
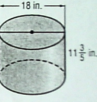
- 
- 
- 
- 
- 
- 
- 
- 
- 
- 
- 
- 

13. cube: edge length, 11 m
 14. rectangular prism: length, 9 cm; width, 13 cm; height, 18.4 cm
 15. cylinder: radius, 9.4 mm; height, 15 mm
 16. cylinder: diameter, 28 in.; height, 12.6 in.

© Glencoe/McGraw-Hill 408 Mathematics: Applications and Concepts, Course 2

7

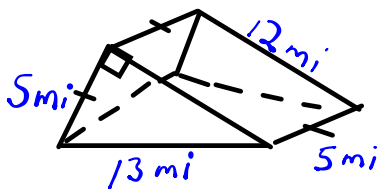

Attachments

Worksheet - Surface Area of Prisms and Cylinders.pdf

Worksheet - Surface Area of Pyramids and Cones.pdf

SA Prisms and Pyramids.pdf