

Determining the Surface Area of a Composite Object



To calculate the surface area of a composite object, the first step is to determine the faces that comprise the surface area. Then calculate the sum of the areas of these faces.

EXAMPLE #1: Determine the surface area of this composite object to the nearest square foot.



SOLUTION

(Erase to reveal)

The surface area of the composite object is approximately 88 square feet.

Sphere

$$SA = 4\pi r^2$$

$$SA = 4\pi (2\text{ft})^2$$

$$SA = 50.265 \text{ft}^2$$

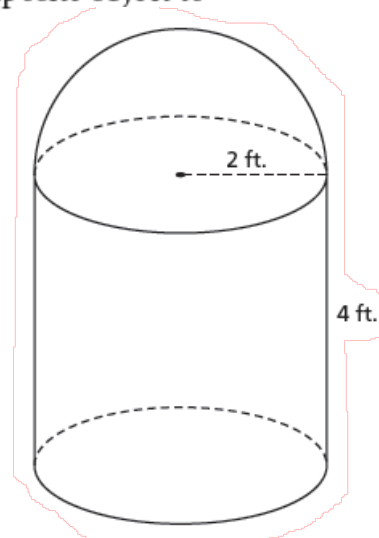

1.7 Solving Problems Involving Objects

$$\downarrow \frac{1}{2} SA = 25.13 \text{ft}^2$$

Cylinder

$$SA = 2\pi r^2 + 2\pi rh$$

$$SA = \pi r^2 + 2\pi rh$$

$$= \pi (2\text{ft})^2 + 2\pi (2\text{ft})(4\text{ft})$$

$$= 62.8 \text{ft}^2$$

$$T_{SA} = 25.13 \text{ft}^2 + 62.8 \text{ft}^2$$

$$= 88 \text{ft}^2$$

EXAMPLE #2: Solving a Problem Related to a Composite Object

A cabane à sucre is a composite object formed by a rectangular prism with a right triangular prism as its roof. Determine the surface area of the cabane à sucre in square yards.

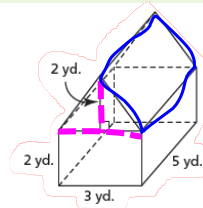

SOLUTION
(Erase to reveal)

Rect. prism

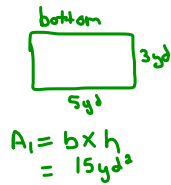

side/side

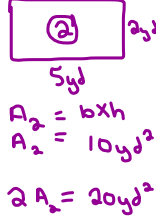

front/back

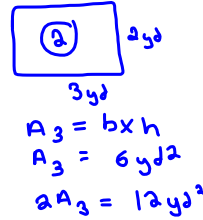

1.7 Solving Problems Involving Objects

$$\begin{aligned} TSA &= A_1 + 2A_2 + 2A_3 \\ &= 15 + 20 + 12 \\ &= 47 \text{ yd}^2 \end{aligned}$$

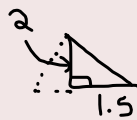
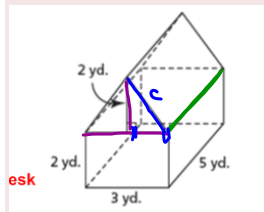

$$\begin{aligned} c &= \sqrt{2^2 + 1.5^2} \\ c &= 2.5 \end{aligned}$$

Tri prism:

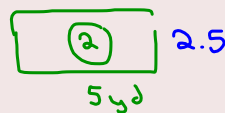
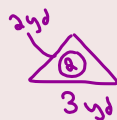

$$A_{\Delta} = \frac{b \times h}{2}$$

$$\begin{aligned} A_{\square} &= b \times h \\ &= 5 \text{ yd} \times 2.5 \text{ yd} \end{aligned}$$

$$A_{\Delta} = \frac{3 \times 2}{2}$$

$$A_{\square} = 12.5 \text{ yd}^2$$

$$A_{\Delta} = 3 \text{ yd}^2$$

$$2A_{\square} = 25 \text{ yd}^2$$

$$2A_{\Delta} = 6 \text{ yd}^2$$

$$\begin{aligned} TSA_2 &= 6 \text{ yd}^2 + 25 \text{ yd}^2 \\ &= 31 \text{ yd}^2 \end{aligned}$$

So

$$\begin{aligned} TSA_1 + TSA_2 &= 47 \text{ yd}^2 + 31 \text{ yd}^2 \\ &= 78 \text{ yd}^2 \end{aligned}$$

TRY THIS ONE...

A tool shed is formed by a rectangular prism with a triangular prism as its roof. Determine the surface area of the tool shed to the nearest square foot.

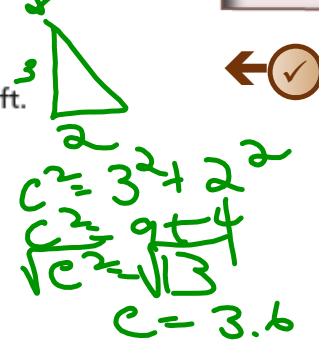
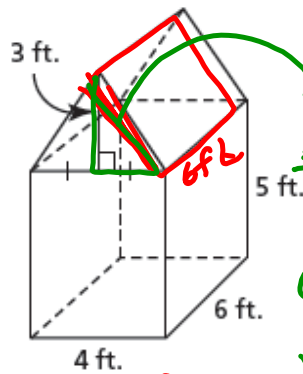

Prism

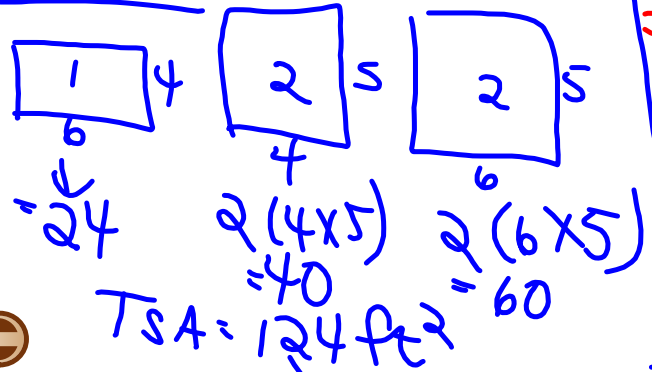

Roof

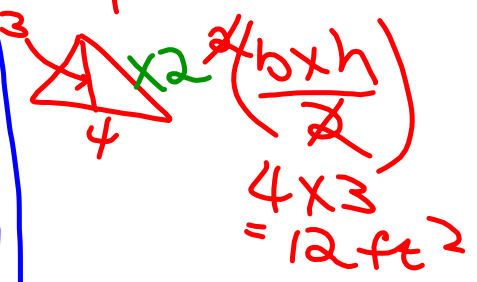

1.7 Solving Problems Involving Objects

$$TSA = 124 + 55.2$$

$$= 179.2 \text{ ft}^2$$

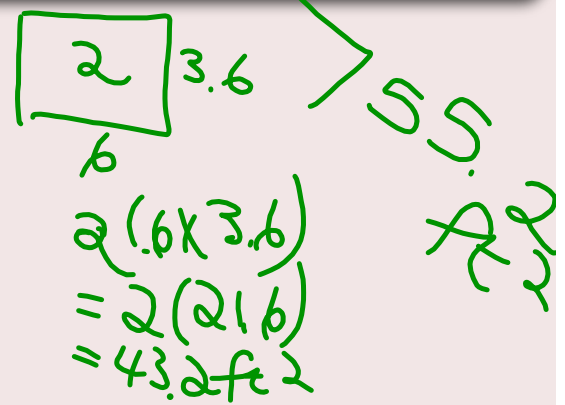

HOMWORK...



#1. Determine the surface area of each composite object to the nearest square unit.

a) right cylinder and right cone

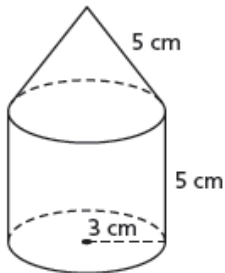

b) right square prism and right square pyramid

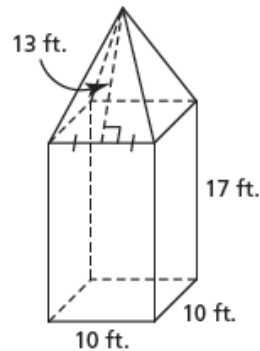

c) right square prism and right cylinder

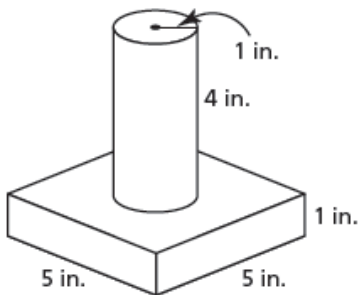

d) right cone and hemisphere

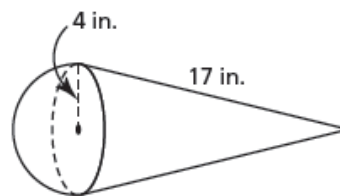

Solutions...

- #1. a) 170 cm^2 b) 1040 ft.^2
 c) 95 in.^2 d) 314 in.^2

Attachments

Practice - Converting Measurements.pdf

Worksheet - Finding Surface Area of a Composite Object.docx